



Department of Public Works

September 9, 2022

Arkansas Energy and Environment
Environmental Quality Department
Engineering Department
5301 Northshore Drive
North Little Rock, AR 72118-5317

Wastewater Department
Kathryn Catlin
Wastewater Systems Manager
1508 Silver Valley Road
Harrison, Arkansas 72601
kcatlin@harrisonar.gov

RE: Notification of Clarifier Repair
NPDES Permit No.: AR0034321

The purpose of this correspondence is to notify Arkansas Energy and Environment, Environmental Quality Department that the City of Harrison will be repairing the existing primary clarifier through rebuilding the internal mechanisms. Rebuild-It Service Group, the company that completed repairs on the existing two final clarifiers in 2019, will be conducting the repairs (see attached proposal and schematic).

The repair project is presently scheduled to begin on November 7, 2022 and will take six to seven days to complete. During this time period we will be bypassing the primary clarifier. If there are any additional requirements or any additional information needed for this project, please contact me as soon as possible. Thank you.

Sincerely,

A handwritten signature in black ink that reads 'Kathryn Catlin'.

Kathryn Catlin
Wastewater Systems Manager



PRICING:

Pricing for (1) 70' dia. clarifier as described above.	\$124,116.00
Labor for removal and installation of new 70' clarifier	\$74,877.00

Total \$ 198,993.00

Adders:

New FRP weir, baffles, baffles support and mounting hardware	\$14,875.00	<i>wsp</i>
Labor to install weirs and baffles during same mobilization as clarifier	\$18,991.00	<i>wsp</i>

Handrail around walkway and half way on outer clarifier (replacing existing)
 installed.....\$26,988.00 *wsp*
 Includes fasteners and installation.

Service platform to mount to existing walkway installed.....\$23,774.00
wsp

All Address Accepted
Wang
03-25-2022

Note: Must be installed during the same mobilization.

SCHEDULE:

Submittals: 3 - 4 weeks.
 Delivery of drive unit and steel components: 15 - 17 weeks after receipt of approved
 submittals.
 Labor services: 8 - 11 days on site with weir & baffle installation.
 Check-out services: 1 day

Please be sure to reference this quotation number and date on your purchase order.

Remit order to:

Rebuild-it Services Group, LLC.
 P.O. Box 1493
 West Jordan, Utah 84084
 Attention: Candace King, cking@rebuild-it.com

100-98-54400
KC
4/13/2022
PO# 2226829



PROPOSAL DATE: March 8, 2022

PROPOSAL NUMBER: Q123580-B

PREPARED FOR:

Harrison, AR WWTP
1508 Silver Valley Road
Harrison, AR 72601
Attention: Kathryn Catlin, MBA
PH: 870-741-5527
E-Mail: Kathryn.catlin@cityofharrison.com

SCOPE OF WORK:

Replace underwater steel and drive for a 70' dia. Dorr-Oliver Clarifier.

PREPARED BY:

Rebuild-it Services Group, LLC.
4188 West Nike Drive
West Jordan, Utah 84088
Terry A. Reyburn
Main: (888) 709-5676
Direct: (385) 235-6924
Mobile: (801) 828-5369
E-Mail: treyburn@rebuild-it.com
Website: rebuild-it.com



PROJECT SUMMARY:

Rebuild-it Services Group, LLC. (RSG) is pleased to offer the following proposal to provide replacement underwater steel, weirs & baffles and the drive unit for an existing 70' dia. Dorr-Oliver drive unit. Serial No. 80065-1. We will also include our professional turn-key labor services.

SCOPE OF WORK:

Dorr-Oliver 70' dia. Clarifier S/N 80065-1.

To include the following:

- RSG CM30 drive assembly – 100% torque rating: 30,000 ft-lbs at 0.10 RPM.
 - 30" nominal pitch diameter cast iron main gear, newly designed for optimal performance and strength.
 - Cast iron main support base, for optimal performance and longevity.
 - Planetary input assembly with redundant integral load cell for torque protection.
 - 1.0 Horsepower motor, severe duty and 10:1 VFD turndown rated.
 - Control Panel- NEMA 4X rated stainless steel control panel, with strain gauge display, VFD, start/stop, and disconnect. Display supports 4-20 ma output signal.
- Center column, mild steel
- Cage 2'-10" sq.
- Rake arms with blades and 304SS squeegees with 304SS fasteners
- Feedwell with supports, mild steel.
- Skimming mechanism, upgrade to the new RGS premium skimmer assembly.
- Weirs and Baffles, FRP with FRP supports and stainless-steel hardware and anchors. (Optional Adder)
- Freight to job site
- 2-year warranty
- Engineering time
- Premium coating system (see details below)
- O&M Manual.

SURFACE PREPARATION AND PAINT:

Drive unit: Surface preparation of SSPC-SP6 following by two (2) coats of Tnemec 161 to a 4-6 mils DFT with a final coat of a UV protected industrial grade polyurethane coating to a 6 mils minimum DFT. Color: Pencil Gray.

Submerged steel: Surface preparation of SSPC-SP10 followed by Two (2) coats of Tnemec N69 hi-build epoxy to 4-6 mils DFT.

EXCLUDED ITEMS FROM SCOPE OF SUPPLY:

- Bridge with platform, walkway and scum box to be reused.
- Finishing painting
- Electrical controls, mounting plates, brackets, conduit, wiring, mounting channels, light posts, photocells, etc.
- Concrete work
- Lubricating oils / greases
- Bi-metallic protection for aluminum handrail, floor plating.
- Access stairways, walkways, gratings, handrailing, etc. outside the tank.
- Scum spray systems, or other water piping.
- Control panels except as specifically noted.
- Parts not mentioned above





RSG TURN-KEY LABOR SERVICES:

The scope of work for this project is as follows:

- Site mobilization and travel time to the job site.
- Removal of existing mechanism.
- Installation of new center column, cage, rakes, feedwell & skimming mechanism.
- Install new drive unit.
- Install existing walkway bridge & platform.
- Crane, mats, rigging equipment as needed.
- Clarifier tracking including rake and drive leveling.
- Touch up paint only.
- Aid during start-up & testing
- A foreman/safety QC manager will be on site throughout the project.
- Work to be performed in one (1) mobilization.
- Demobilization of personnel and equipment.
- Field services check out and start-up service.

This proposal excludes the following items:

- Electrical disconnect and reconnect.
- Installation of weirs & baffles (option listed below).
- Permits, fees, and/or stamped engineering documents.
- Provision of Full-Time Safety & QA/QC manager.
A foreman will be onsite throughout duration of construction activities and provide field coordination.
- Overtime premiums or weekend work.
- Temp facilities including porta-johns, hand wash, temp power, water, and disposal bins to be provided by others.
- Installation of electrical and/or instrumentation to be by others.
- Concrete demolition and/or repair.
- Covered tank or dome; removal of dome or access panels by others.
- Grouting of the tank or concrete work.
- Assumes reasonable access to basins.
- No coating on site- touch up paint only.
- Prevailing wage.
- Hazardous material abatement, handling and/or disposal.
- Any work not specifically included.
- Draining and cleaning of the tank.
- Disposing of old debris/parts.
- Lubrication for drive unit.



PRICING:

Pricing for (1) 70' dia. clarifier as described above.	\$124,116.00
Labor for removal and installation of new 70' clarifier	\$74,877.00

Total \$ 198,993.00

Adders:

New FRP weir, baffles, baffles support and mounting hardware	\$14,875.00
Labor to install weirs and baffles during same mobilization as clarifier	\$18,991.00

Handrail around walkway and half way on outer clarifier (replacing existing)
 installed.....\$26,988.00
 Includes fasteners and installation.

Service platform to mount to existing walkway installed.....\$23,774.00

Note: Must be installed during the same mobilization.

SCHEDULE:

Submittals: 3 - 4 weeks.

Delivery of drive unit and steel components: 15 - 17 weeks after receipt of approved submittals.

Labor services: 8 - 11 days on site with weir & baffle installation.

Check-out services: 1 day

Please be sure to reference this quotation number and date on your purchase order.

Remit order to:

Rebuild-it Services Group, LLC.
 P.O. Box 1493
 West Jordan, Utah 84084
 Attention: Candace King, cking@rebuild-it.com



PRICING AND PAYMENT TERMS:

We appreciate the opportunity to offer our parts & services. Upon receipt of an order, we assure you of our continued interest and service. RSG will provide the best service possible to ensure we exceed your expectations. The actual lead-times are based on the schedule and inventory at the time of ordering as lead times are subject to change according to the current job schedule.

This proposal, including all terms and conditions contained herein, shall become part of any resulting contract or purchase order. Changes to any terms and conditions, including but not limited to submittal and shipment days, payment terms, and escalation clause shall be negotiated at order placement, otherwise the proposal terms and conditions contained herein shall apply.

Terms: If not outline otherwise in the proposal, terms for the parts and/or equipment are 100% due after shipment or service is completed. Net 30 days from shipment or after service is completed. If the project exceeds \$50,000.00 for materials, then the payment terms are 50% up front for engineering and raw materials and 50% due shipment, still net 30 days. The prices are good for **30** days.

Sales Tax: No sales taxes, use taxes, or duties have been included in our pricing. We are required to collect sales tax for the following states: Utah, California, and Washington. If you are not tax exempt, please remit taxes directly to the governing authorities.

Freight: Prices quoted are F.O.B. shipping point with freight prepaid and shipped to a readily accessible location nearest to the jobsite, unless otherwise indicated, unless otherwise noted. All claims for damage or loss in shipment shall be initiated by purchaser.

Shipment: Shipping times noted within this proposal are estimated and will be finalized once an order has been received and accepted.

Field Service: Prices do not include field service unless noted in the rebuild scope of work description. Additional field service is available at \$1,200.00 per day plus expenses.

Carbon and Stainless-Steel Escalation: Any material price increase from the proposal date to material procurement that is greater increase from the stated price of more than 5% are herein subject to price escalation. The escalation shall be based on the increase of cost, without additional profit. Any revisions or changes requested by the customer will be priced on a case-by-case basis. The steel pricing and escalations are based on the material index located at www.steelbb.com.



WARRANTY & TERMS AND CONDITIONS:

Parts and/or Equipment manufactured or rebuilt and sold by Rebuild-it Services Group, once paid for in full, is backed by the following warranty:

For the benefit of the original user, RSG warrants all new parts and equipment sold or rebuilt by RSG, LLC. to be free from defects in material and workmanship, and will replace or repair, F.O.B. its

factories or other location designated by it, any part or parts returned to which RSG's examination shall show to have failed under normal use and service by the original user within three (3) years following initial start-up, or three (3) years and six (6) months from shipment to the purchaser, whichever occurs first, unless otherwise mentioned.

Such repair or replacement shall be free of charge for all items except for those items such as resin, filter media and the like that are consumable and normally replaced during maintenance, with respect to which, repair or replacement shall be subject to a pro-rata charge based upon RSG's estimate of the percentage of normal service life realized from the part. RSG's obligation under this warranty is conditioned upon its receiving prompt notice of claimed defects, which shall in no event be later than thirty (30) days following expiration of the warranty period, and is limited to repair or replacement as aforesaid.

This warranty is expressly made by RSG and accepted by purchaser in lieu of all other warranties, including warranties of merchantability and fitness for particular purpose, whether written, oral, express, implied, or statutory. RSG shall not be liable for normal wear and tear, corrosion, or any contingent, incidental, or consequential damage or expense due to partial or complete inoperability of its equipment for any reason whatsoever.

This warranty shall not apply to equipment or parts thereof which have been altered or repaired outside of a RSG factory, or damaged by improper installation, application, or maintenance, or subjected to misuse, abuse, neglect, accident, or incomplete adherence to all manufacturer's requirements, including, but not limited to, Operations & Maintenance Manual guidelines & procedures. When buying a drive or drive rebuild, if the drive control has not been hooked up or disabled, the warranty on the drive is not valid. If the recommended or equivalent oil is not used or correct quantity is not applied, it will void the warranty. It is the customers responsibility to grease and lubricate the drives, if this is not done on a regular basis it will void the warranty.

This warranty applies only to equipment made or sold by Rebuild-it Services Group, LLC (RSG). RSG makes no warranty with respect to parts, accessories, or components purchased by the customer from others. The warranties which apply to such items are those offered by their respective manufacturers.

CONFIDENTIALITY:

All the information in this quotation is confidential and has been prepared for your use solely in considering services described. Transmission of all or any parts of this information to others or use by you for other purposes is unauthorized without our written consent.



Proposal No. Q123580-B

TERMS AND CONDITIONS:

Terms and Conditions appearing in any order based on this proposal which are inconsistent herewith shall not be binding on Rebuild-it Services Group (RSG). The sale and purchase of equipment described herein shall be governed exclusively by the foregoing proposal and the following provisions:

1. SPECIFICATIONS: RSG is furnishing its standard equipment as outlined in the proposal and as will be covered by final approved drawings if applicable. The equipment will, however, meet the general intention of the mechanical specifications of these documents.

2. ITEMS INCLUDED: This proposal includes only the equipment specified herein and does not include erection, installation, accessories, nor associated materials such as controls, piping, etc., unless specifically listed.

3. PRICE AND DELIVERY: All selling prices quoted are subject to change without notice after 30 days from the date of this proposal unless specified otherwise. Unless otherwise stated, all prices are F.O.B. RSG or its supplier's shipping points. All claims for damage, delay or shortage arising from such equipment shall be made by Purchaser directly against the carrier. When shipments are quoted F.O.B. job site or other designation, Purchaser shall inspect the equipment shipped, notifying RSG of any damage or shortage within forty-eight hours of receipt, and failure to so notify RSG shall constitute acceptance by Purchaser, relieving RSG of any liability for shipping damages or shortages.

4. PAYMENTS: All invoices are net 30 days. Delinquencies are subject to a 1.5 percent service charge per month or the maximum permitted by law, whichever is less on all past due accounts. Pro rata payments are due as shipments are made. If shipments are delayed by the Purchaser, invoices shall be sent on the date when RSG is prepared to make shipment and payment shall become due under standard invoicing terms. If the work to be performed hereunder is delayed by the Purchaser, payments shall be based on the purchase price and percentage of completion. Products held for the Purchaser shall be at the risk and expense of the Purchaser. Unless specifically stated otherwise, prices quoted are for equipment only. These terms are independent of and not contingent upon the time and manner in which the Purchaser receives payment from the owner.

5. INSTALLATION SUPERVISION: Prices quoted for equipment do not include installation supervision, unless otherwise noted. RSG recommends and will, upon request, make available, RSG's then current rate, an experienced installation supervisor to act as the Purchaser's employee and agent to supervise installation of the equipment. Purchaser shall at its sole expense furnish all necessary labor equipment, and materials needed for installation.

Responsibility for proper operation of equipment, if not installed by RSG or installed in accordance with RSG or original manufacture instructions and inspected and accepted in writing by RSG or manufacture representing RSG.

RSG will supply the safety devices described in this proposal or shown in RSG's or manufacture represented drawings furnished as part of this order but excepting these, RSG shall not be required to supply or install any safety devices whether required by law or otherwise. The Purchaser hereby agrees to indemnify and hold harmless RSG from any claims or losses arising due to alleged or actual insufficiency or inadequacy of the safety devices offered or supplied hereunder, whether specified by RSG or Purchaser, and from any damage resulting from the use of the equipment supplied hereunder.

6. ACCEPTANCE OF PRODUCTS: Products will be deemed accepted without any claim by Purchaser unless written notice of non-acceptance is received by RSG within 30 days of delivery if shipped F.O.B. point of shipment, or 48 hours of delivery if shipped F.O.B. point of destination. Such written notice shall not be considered received by RSG unless it is accompanied by all freight bills for said shipment, with Purchaser's notations as to damages, shortages and conditions of equipment, containers, and seals. Non-accepted products are subject to the return policy stated below.

7. TAXES: Any federal, state, or local sales, use or other taxes applicable to this transaction, unless specifically included in the price, shall be for Purchaser's account.

8. INSURANCE: From date of shipment until the invoice is paid in full, Purchaser agrees to provide and maintain at its expense, but for RSG benefit, adequate insurance including, but not limited to, builders risk insurance on the equipment against any loss of any nature whatsoever.

9. SHIPMENTS: Any shipment of delivery dates recited represent RSG's best estimate but no liability, direct or indirect, is assumed by RSG for failure to ship or deliver on such dates.



Proposal No. Q123580-B

RSG shall have the right to make partial shipments; and invoices covering the same shall be due and payable by Purchaser in accordance with the payment terms thereof. If Purchaser defaults in any payment when due hereunder, RSG may, without incurring any liability therefore to Purchaser or Purchaser's customers, declare all payments immediately due and payable with maximum legal interest thereon from due date of said payment, and at its option, stop all further work and shipments until all past due payments have been made, and/or require that any further deliveries be paid for prior to shipment.

If Purchaser requests postponements of shipments, the purchase price shall be due and payable upon notice from RSG that the equipment is ready for shipment; and thereafter any storage or other charge RSG incurs on account of the equipment shall be for the Purchaser's account.

If delivery is specified at a point other than RSG or its supplier's shipping points, and delivery is postponed or prevented by strike, accident, embargo, or other cause beyond RSG reasonable control and occurring at a location other than RSG or its supplier's shipping points, RSG assumes no liability in delivery delay. If Purchaser refuses such delivery, RSG may store the equipment at Purchaser's expense. For all purposes of this agreement such tender of delivery or storage shall constitute delivery.

10. SURFACE PREPARATION AND PAINTING: If furnished, shop primer paint is intended to serve only as minimal protective finish. RSG will not be responsible for the condition of primed or finish painted surfaces after equipment leaves its shops. Purchasers are invited to inspect paint in shops for proper preparation and application prior to shipment. RSG assumes no responsibility for field surface preparation or touch-up of shipping damage to paint. Painting of fasteners and other touch-up to painted surfaces will be by Purchaser's painting contractor after mechanism installation.

11. RETURN OF PRODUCTS: No products may be returned to RSG without RSG's prior written permission. Said permission may be withheld by RSG at its sole discretion.

12. BACK CHARGES: RSG will not approve or accept back charges for labor, materials, or other costs incurred by Purchaser or others in modification, adjustment, service, or repair of RSG furnished materials unless such back charge has been authorized in advance in writing by a RSG employee and a purchase order, or work requisition signed by RSG.

13. INDEMNIFICATION: Purchaser agrees to indemnify RSG from all costs incurred, including but not limited to court costs and reasonable attorney fees, from enforcing any provisions of this contract, including but not limited to breach of contract or costs incurred in collecting monies owed on this contract.

14. ENTIRE AGREEMENT: This proposal expresses the entire agreement between the parties hereto superseding any prior understandings and is not subject to modification except by a writing signed by an authorized officer of each party.

15. EXTENDED STORAGE: Extended storage instructions will be part of information provided to shipment. If equipment installation and start-up is delayed more than 30 days, the provisions of the storage instructions must be followed to keep WARRANTY in force.

16. LIABILITY: Professional liability insurance, including but not limited to, errors and omissions insurance, is not included. In any event, liability for errors and omissions shall be limited to the lesser of 25,000USD or the value of the particular piece of equipment (not the value of the entire order) supplied by RSG against which a claim is sought.

17. ARBITRATION NEGOTIATION: Any controversy or claim arising out of or relating to the performance of any contract resulting from this proposal or contract issued, or the breach thereof, shall be settled by arbitration in accordance with the Construction Industry Arbitration Rules of the American Arbitration Association, and judgment upon the award rendered by the arbitrator(s) may be entered to any court having jurisdiction.

ACCEPTED BY PURCHASER

Customer Name: _____

Customer Address: _____

Contact Name: _____

Contact Phone: _____

Contact Email: _____

Signature: _____

Printed Name: _____

Title: _____

Date: _____

Ø 70'-0" **CLARIFIER**

- 1. WALKWAY:
RE-USE EXISTING
NEW PLATFORM
MATERIAL: A36 STEEL
WEIGHT: 700 LBS
ALUM. HANDRAIL AND GRATING
- 2. CENTER COLUMN:
MATERIAL: A36 STEEL
DIAMETER: Ø 2'-0"
(4) FOUR INLET PORTS SIZED FOR
135% OF COLUMN INSIDE AREA
WEIGHT: 2,700 LBS
- 3. DRIVE CAGE:
MATERIAL: A36 STEEL
WEIGHT: 1,300 LBS
- 4. FEEDWELL W/ SUPPORTS:
MATERIAL: A36 STEEL
DIAMETER: Ø 12'-0"
W/ (4) FOUR BAFFLED SCUM PORTS
WEIGHT: 2,850 LBS
- 5. RAKE ARM:
MATERIAL: A36 STEEL
WEIGHT: 1,200 LBS (PER ARM)
- 6. RAKE BLADE W/ SQUEEGEES:
RAKE BLADES: A36 STEEL
WEIGHT: 450 LBS (PER ARM)
SQUEEGEES: 304 STAINLESS STEEL
- 7. SCUM BOX:
RE-USE EXISTING
- 8. SKIMMER W/ SUPPORTS:
MATERIAL: A36 STEEL
WEIGHT: 850 LBS
- 9. DRIVE:
RSG CM30
- 10. EXISTING TANK
- 11. WEIRS & BAFFLES
MATERIAL: FRP
- 12. HANDRAIL FOR TANK
MATERIAL: ALUMINUM

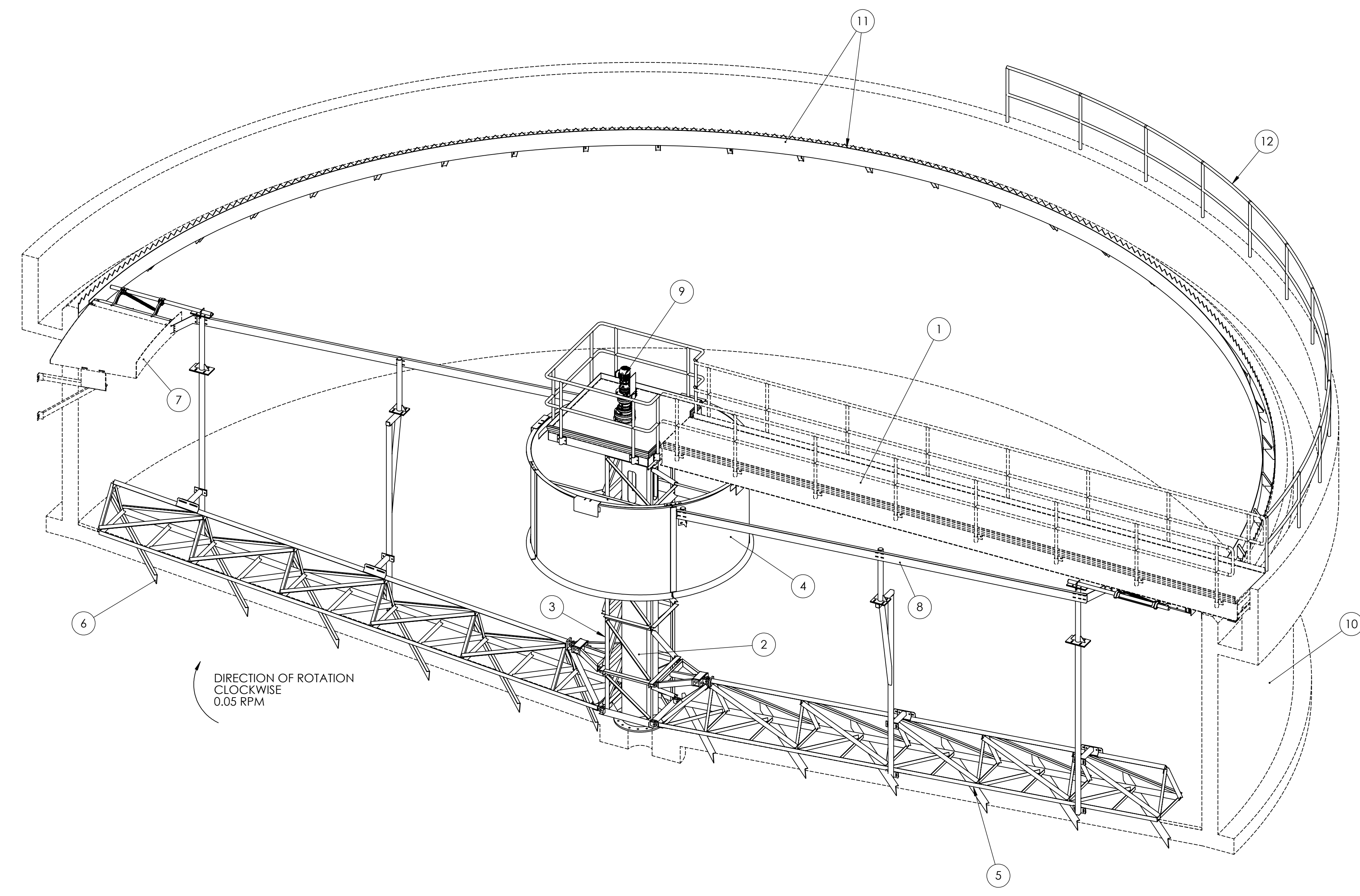

ILLUSTRATIVE VIEW

		INTERPRET DIMENSIONS AND TOLERANCES PER ANSI Y14.5 UNLESS OTHERWISE SPECIFIED DIMENSIONS ARE IN INCHES	THIS DOCUMENT CONTAINS INFORMATION WHICH IS PROPRIETARY TO REBUILD-IT SERVICES GROUP, LLC. NO INFORMATION CONTAINED HEREIN, NOR ANY PART OF SUCH INFORMATION MAY BE REPRODUCED, TRANSFERRED TO OTHER DOCUMENTS OR DISCLOSED TO OTHERS FOR ANY PURPOSE WITHOUT THE EXPRESS WRITTEN AUTHORIZATION OF REBUILD-IT SERVICES GROUP, LLC.
ANGULAR .X = ±5° .XX = ±1° .XXX = ±0.5°	DECIMAL .X = ± 0.1 .XX = ± 0.03 .XXX = ± 0.010	FRACTIONAL 0 TO 30 FT ± 1/16" 30 TO 60 FT ± 1/8" OVER 60 FT ± 1/4"	CERTIFIED FOR HARRISON, AR 70'-0" DIA X 14'-0" SWD CLARIFIER REPLACEMENT
REBUILD-IT SERVICES GROUP MIDVALE, UTAH USA			
DSGN BY: JDG DATE: 5/3/2022 APPVD: DATE:	FILE NAME: 51470-100 REF. FROM: DO NOT SCALE PRINT PROJECT NUMBER: 51470 DRAWING NUMBER: 100 SHEET NUMBER: 1 OF 4 REVISION: 0		

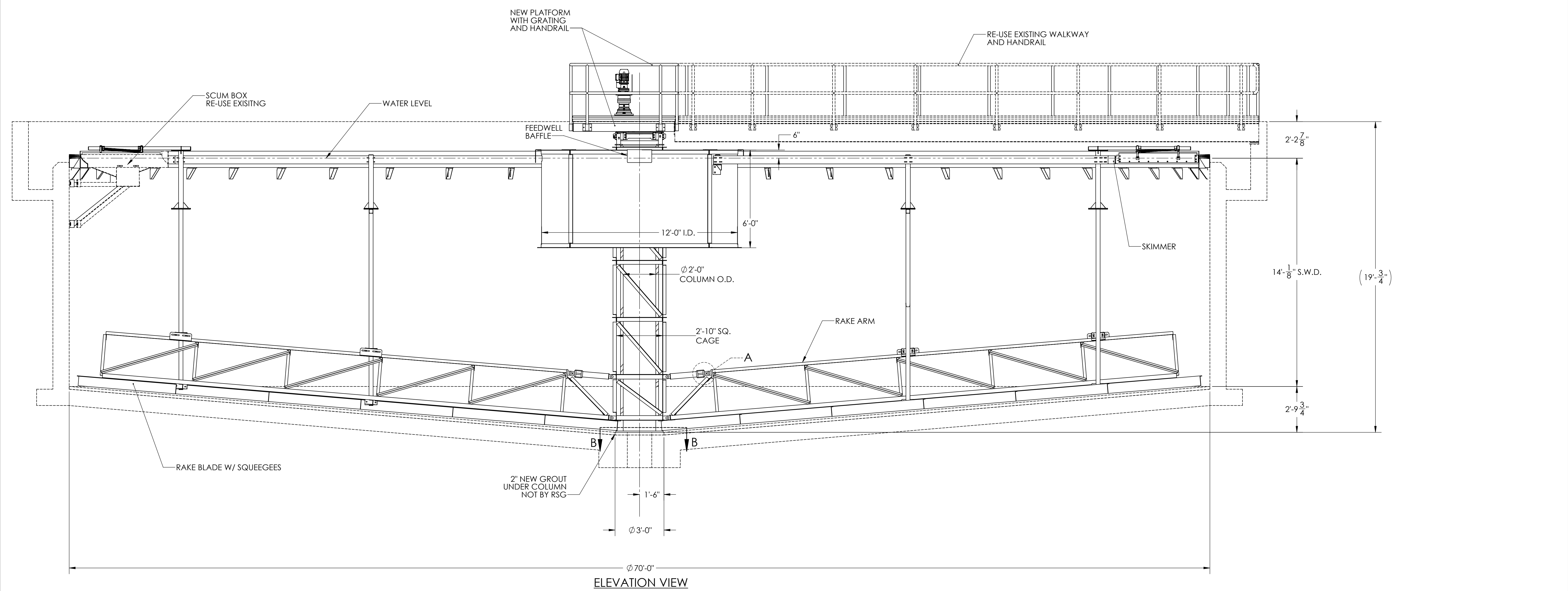
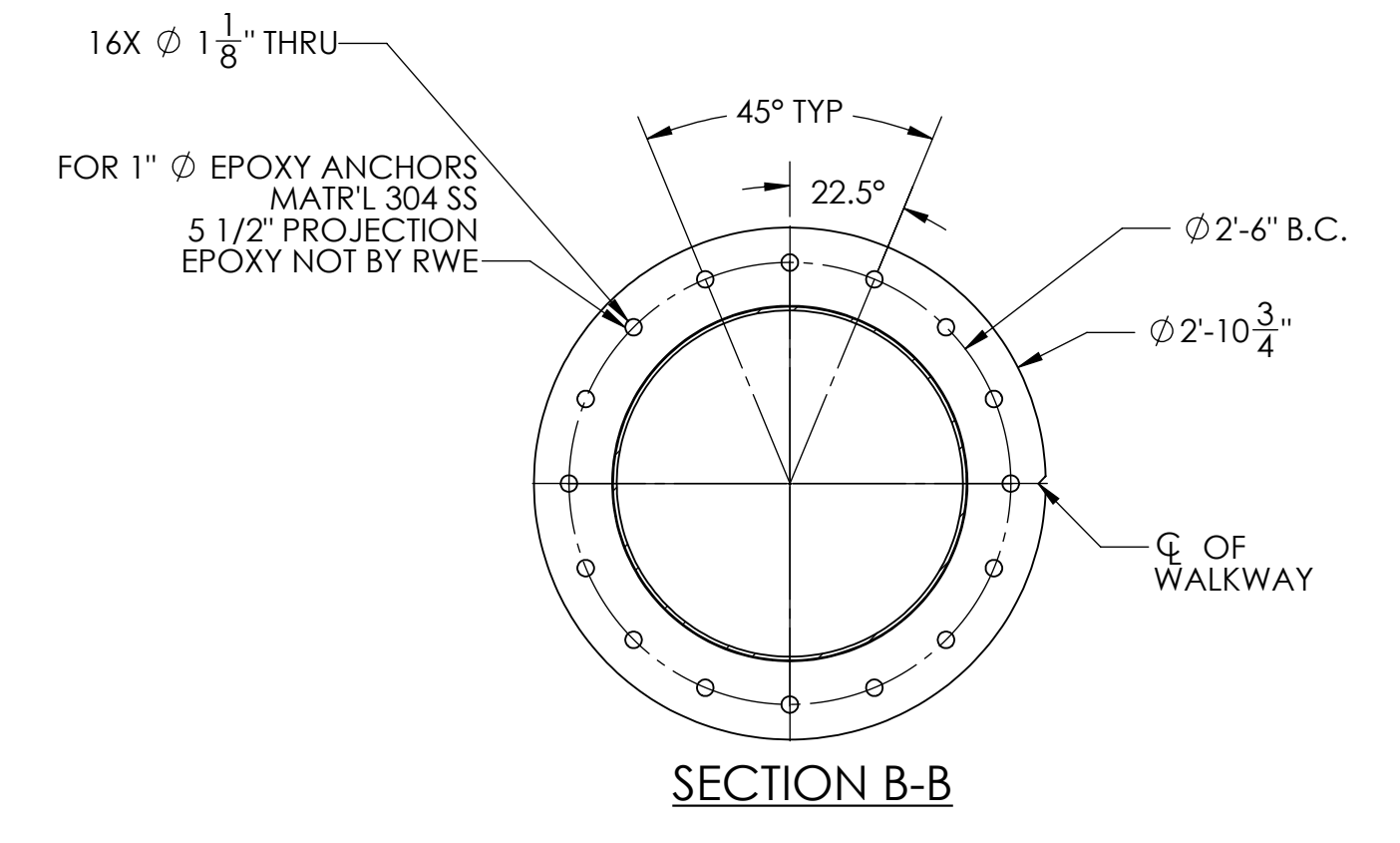
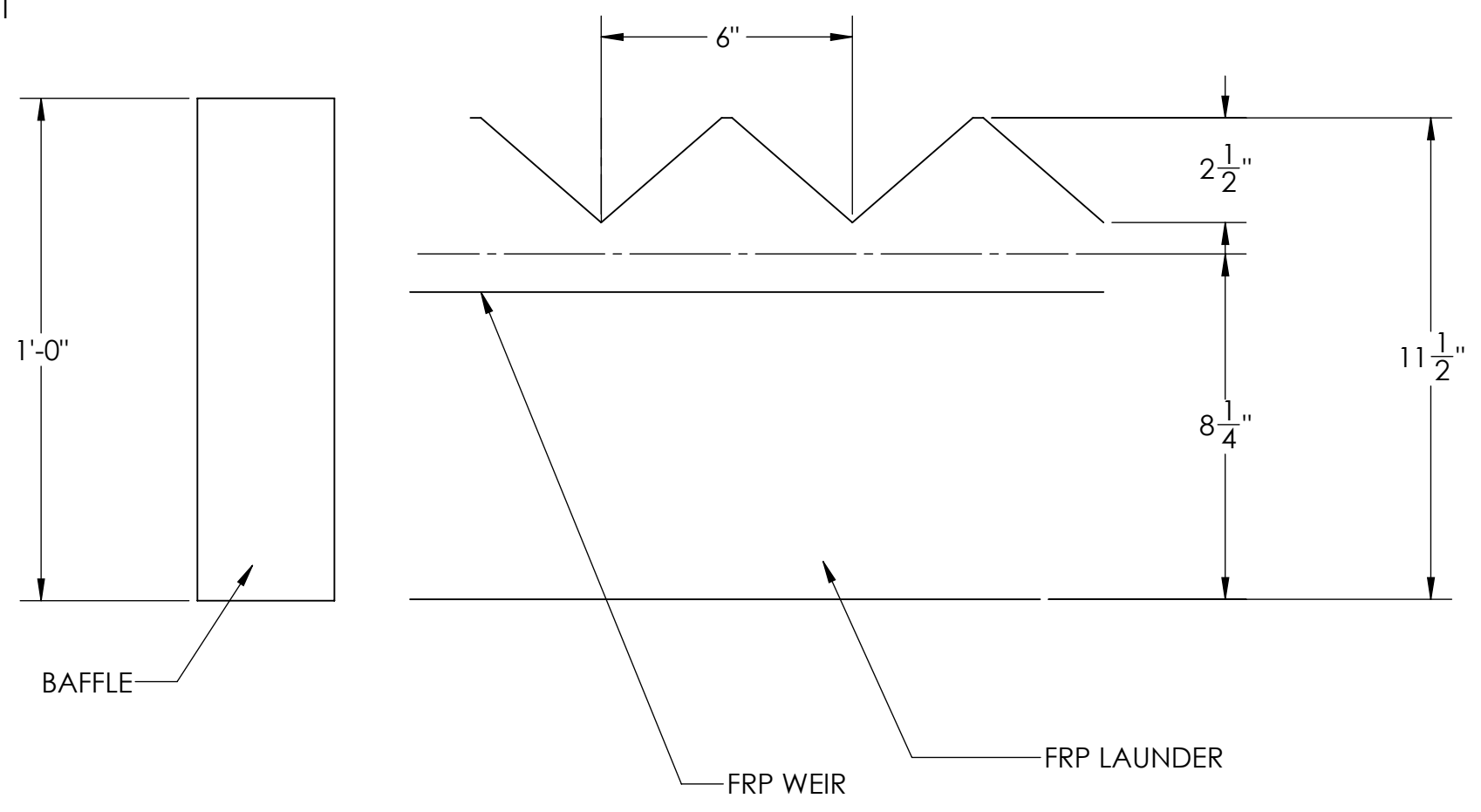
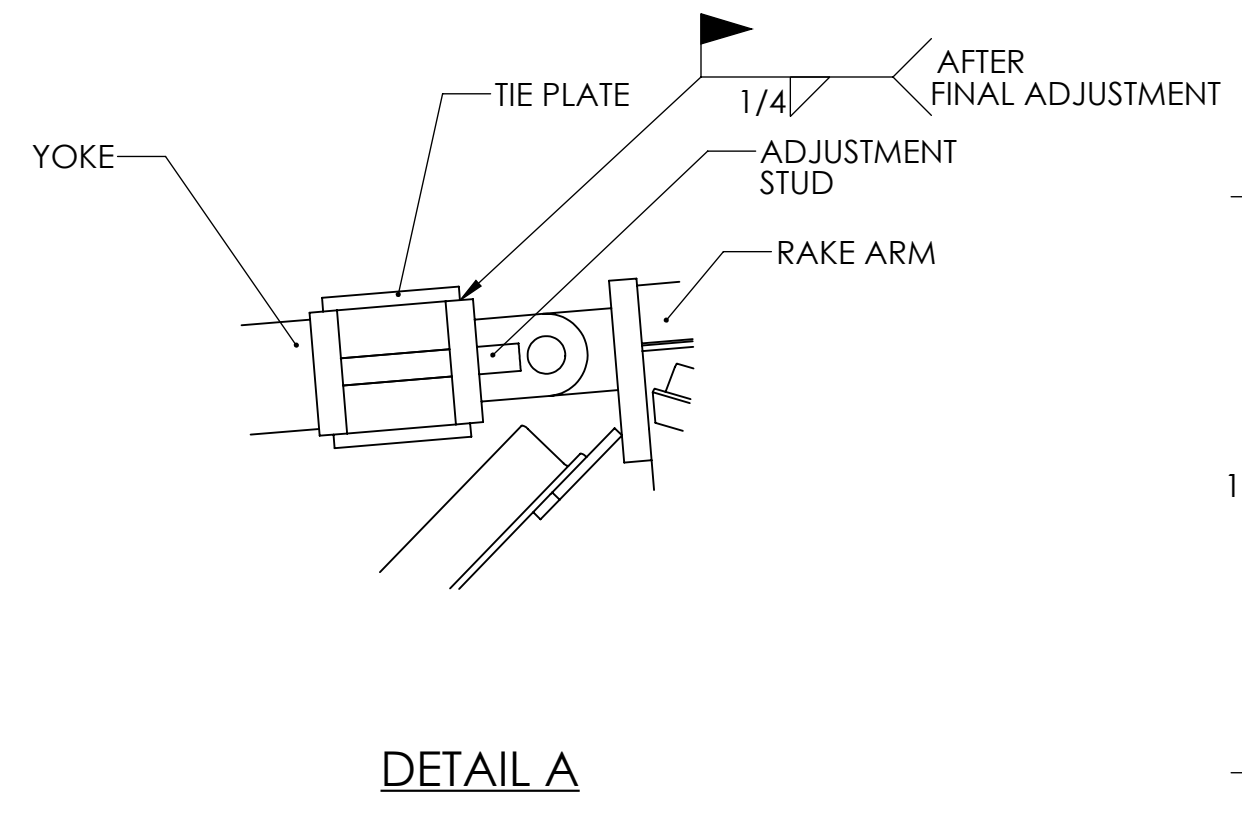
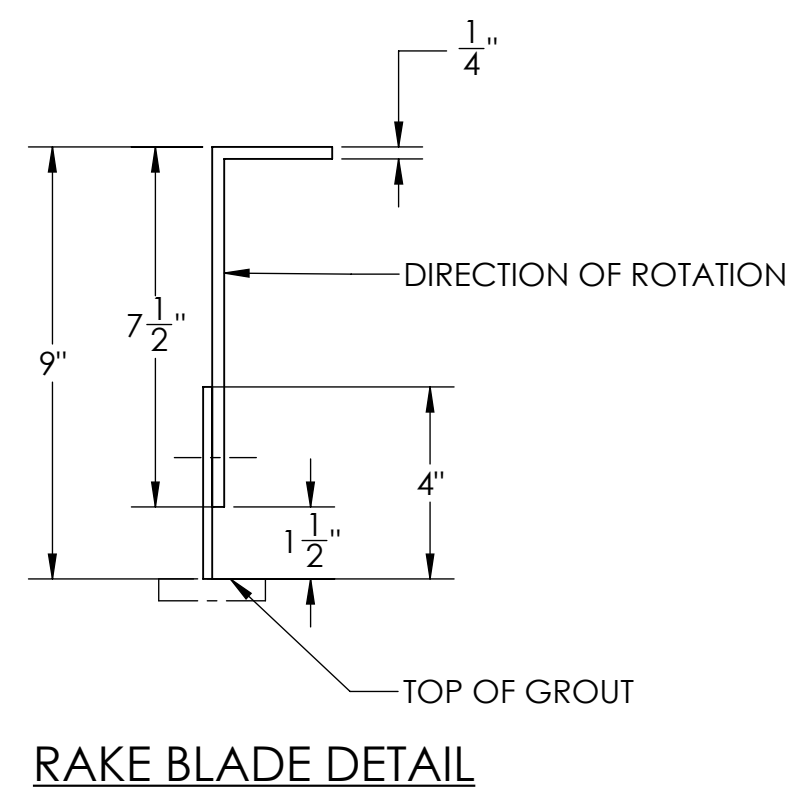

THIS DOCUMENT CONTAINS INFORMATION WHICH IS PROPRIETARY TO REBUILD-IT SERVICES GROUP, LLC. NO INFORMATION CONTAINED HEREIN, NOR ANY PART OF SUCH INFORMATION MAY BE REPRODUCED, TRANSFERRED TO OTHER DOCUMENTS OR DISCLOSED TO OTHERS FOR ANY PURPOSE WITHOUT THE EXPRESS WRITTEN AUTHORIZATION OF REBUILD-IT SERVICES GROUP, LLC.

REBUILD-IT SERVICES GROUP MIDVALE, UTAH USA	DSGN BY:	JDG	FILE NAME:	51470-100	REF. FROM:	DO NOT SCALE PRINT
	DATE:	5/3/2022	PROJECT NUMBER:	51470	DRAWING NUMBER:	100
	APPVD:		SHEET NUMBER:	2 OF 4	REVISION:	0
	DATE:					

8

7

6

5

4

3

2

1

D

D

C

C

B

B

A

A

$\phi 69'-11\frac{1}{2}"$
 WEIRS I.D.
 $\phi 68'-7\frac{1}{2}"$
 BAFFLES I.D.

$R37'-11\frac{1}{16}"$
 INSIDE
 5'-0"
 11X
 TANK HANDRAIL
 5'-0"
 11X
 $R37'-11\frac{1}{16}"$
 INSIDE

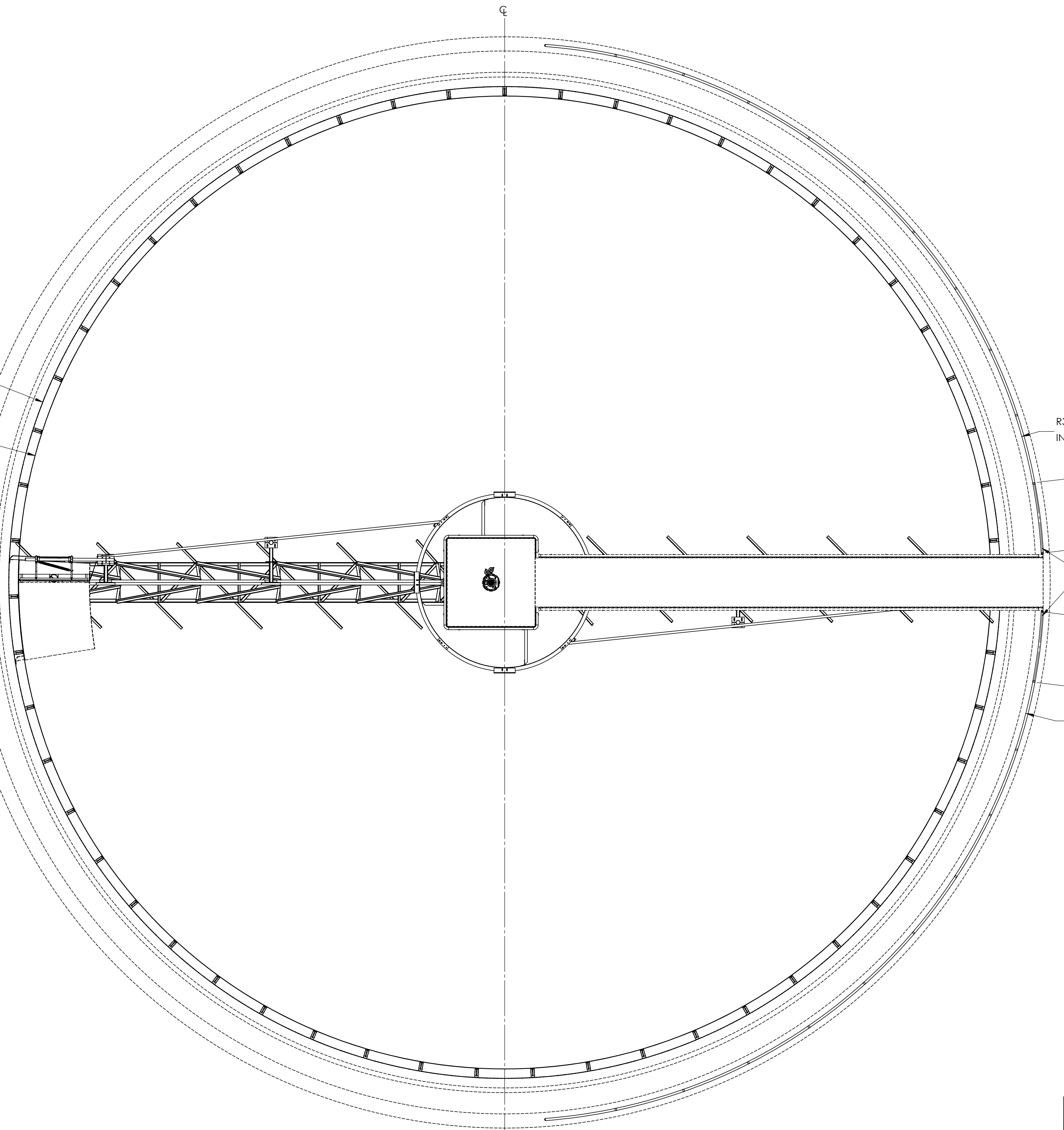

THIS DOCUMENT CONTAINS INFORMATION WHICH IS PROPRIETARY TO REBUILD-IT SERVICES GROUP, LLC. NO INFORMATION CONTAINED HEREIN, NOR ANY PART OF SUCH INFORMATION MAY BE REPRODUCED, TRANSFERRED TO OTHER DOCUMENTS OR DISCLOSED TO OTHERS FOR ANY PURPOSE WITHOUT THE EXPRESS WRITTEN AUTHORIZATION OF REBUILD-IT SERVICES GROUP, LLC.

REBUILD-IT SERVICES GROUP MIDVALE, UTAH USA	DSGN BY:	JDG	FILE NAME:	REF. FROM:	DO NOT SCALE PRINT
	DATE:	5/3/2022	51470-100		
	APPVD:		PROJECT NUMBER	DRAWING NUMBER	SHEET NUMBER
	DATE:		51470	100	3 OF 4

8

7

6

5

4

3

2

1

GENERAL PROJECT NOTES:

1. AN ASTERISK (*) DENOTES VARIANCE FROM CONTRACT DOCUMENTS AND SHOULD BE PARTICULARLY NOTED.
2. THE FOLLOWING DEFINES RESPONSIBILITY OF REBUILD-IT SERVICES GROUP (RSG), WITH REGARDS TO THE INFORMATION AND DIMENSIONS SHOWN IN THE DRAWING. DIMENSIONS, LOADS, AND OTHER INFORMATION ARE PROVIDED TO ACCOMODATE THE EQUIPMENT TO THE STRUCTURE AS SHOWN.
 - A. THE CUSTOMER IS TO PROVIDE REINFORCING STEEL AND DESIGN FOR THE CONCRETE STRUCTURES AND IS TO DETERMINE SIZES TO SUIT LOCAL CONDITIONS.
 - B. THIS DRAWING IS NOT TO BE USED FOR CONSTRUCTION OR INSTALLATION PURPOSES UNLESS IT BEARS THE APPROVAL OF THE OWNER, THE ENGINEER, OR THE AUTHORIZED REPRESENTATIVE.
 - C. THE MECHANISM SHOWN IS DESIGNED FOR THE DIRECTION OF THE ROTATION INDICATED. RSG DOES NOT ASSUME RESPONSIBILITY FOR ANY DAMAGE IF OPERATED IN THE OPPOSITE DIRECTION.
 - D. CHARGES FOR MODIFICATION, ADDITIONS, OR CORRECTIONS TO THE EQUIPMENT WILL NOT BE ACCEPTED BY RSG UNLESS PRIOR APPROVAL IS OBTAINED IN WRITING FROM AN AUTHORIZED RSG REPRESENTATIVE.
 - E. IN THE EVENT THAT THIS IS A REPLACEMENT OF AN EXISTING UNIT, ALL ATTEMPTS HAVE BEEN MADE TO MATCH THE EXISTING DESIGN CRITERIA. IF EXISTING DESIGN CRITERIA IS NOT AVAILABLE, RSG WILL DESIGN THE UNIT TO RSG STANDARDS.
 - F. EVALUATION OF EXISTING TANKS OR REPAIRS ARE NOT A PART OF RSG SCOPE OF SUPPLY UNLESS SPECIFICALLY NOTED.
3. REBUILD-IT SERVICES GROUP DOES NOT FURNISH ELECTRICAL WIRING, CONDUIT, ELECTRICAL EQUIPMENT, PIPING, VALVES OR FITTINGS, LUBRICATING OIL OR GREASE, FIELD PAINTING, FIELD WELDING OR ERECTION. (EXCEPT AS SPECIFICALLY NOTED).
4. SHOP PRIMER PAINT IS INTENDED TO SERVE ONLY AS A PROTECTIVE OR SEALING COAT. AS SUCH, IT AFFORDS THE METAL ONLY MINIMAL PROTECTION AGAINST THE ELEMENTS. RSG CANNOT BE HELD RESPONSIBLE FOR DETERIORATION OF SHOP-PRIMED EQUIPMENT DURING TRANSIT, JOB STORAGE, OR OTHER EXPOSURE TO THE ELEMENTS PRIOR TO APPLICATION OF FINISH COAT(S).
5. SURFACE PREPARATION TO CONSIST OF:
 - A. DRIVE UNIT: SURFACE PREPARATION OF SSPC-SP6 FOLLOWED BY TWO (2) COATS OF TNEMEC 161 TO A 4-6 MILS DFT WITH A FINAL COAT OF A UV PROTECTION INDUSTRIAL GRADE POLYURETHANE COATING TO A 6 MILS MINIMUM DFT. COLOR; PENCEIL GRAY.
 - B. ALL CARBON STEEL NON- IMMERSION SURFACE PREP SSPC-SP6 (COMMERCIAL SANDBLAST CLEANING).
 - C. ALL CARBON STEEL IMMERSION SURFACE PREP SSPC-SP10 (NEAR WHITE SANDBLAST CLEANING) FOLLOWED BY TWO (2) SHOP COAT OF TNEMEC 69 HI-BUILD EPOXY TO A DFT OF 4-6 MILS.
 - D. ALL ALUMINUM, GALVANIZED AND STAINLESS STEEL COMPONENTS WILL BE SHIPPED UNPAINTED.
6. ALL STEEL SHALL BE NEW AND CONFORM TO ASTM SPECIFICATIONS:
 - A. ASTM TYPE: 304/304L STAINLESS STEEL.
 - B. ASTM TYPE: CARBON STEEL.
 - A. ASTM A992 FOR BEAMS
 - B. ASTM A36 FOR ANGLES, CHANNELS, BARS & MISC. SHAPES.
 - C. ASTM A36 OR A283 GRADE "C" FOR PLATES.
 - D. ASTM A500 FOR HOLLOW STRUCTURAL SECTIONS.
 - E. ASTM A53 GRADE "B" FOR PIPES.
 - C. MINIMUM STEEL THICKNESS SHALL BE 1/4" UNLESS SPECIFICALLY NOTED ON THESE DRAWINGS.
7. FOR ADDITIONAL DETAILS REFER TO DRAWING
 - A. 51470-100 SHEETS 1, 2, 3 & 4 - G.A. DETAILS.
8. REBUILD-IT EQUIPMENT SCOPE OF SUPPLY INCLUDES THE FOLLOWING:
 - A. DRIVE UNIT: RSG CM30
 - B. PLATFORM W/ GRATING AND HANDRAIL
 - C. TANK HANDRAIL
 - D. INFLUENT COLUMN
 - E. DRIVE CAGE
 - F. FEEDWELL
 - G. SKIMMER & SUPPORTS
 - H. RAKE ARMS
 - I. RAKE BLADES
 - J. 20 GA 304 SS SQUEEGEES
 - K. FRP LAUNDERS
 - L. FREIGHT
 - M. RELATED 304SS FIELD FASTENERS AND ANCHORS

THIS DOCUMENT CONTAINS INFORMATION WHICH IS PROPRIETARY TO REBUILD-IT SERVICES GROUP, LLC. NO INFORMATION CONTAINED HEREIN, NOR ANY PART OF SUCH INFORMATION MAY BE REPRODUCED, TRANSFERRED TO OTHER DOCUMENTS OR DISCLOSED TO OTHERS FOR ANY PURPOSE WITHOUT THE EXPRESS WRITTEN AUTHORIZATION OF REBUILD-IT SERVICES GROUP, LLC.						
REBUILD-IT SERVICES GROUP MIDVALE, UTAH USA	DSGN BY:	JDG	FILE NAME:	51470-100	REF. FROM:	DO NOT SCALE PRINT
	DATE:	5/3/2022	PROJECT NUMBER:	51470	DRAWING NUMBER:	100
	APPVD:		SHEET NUMBER:	4 OF 4	REVISION:	0
	DATE:					